

R/A COAX PLUG+HOUSING

CABLE 2.6/50

R197.120.A00

Series : SMB
CARLOCK

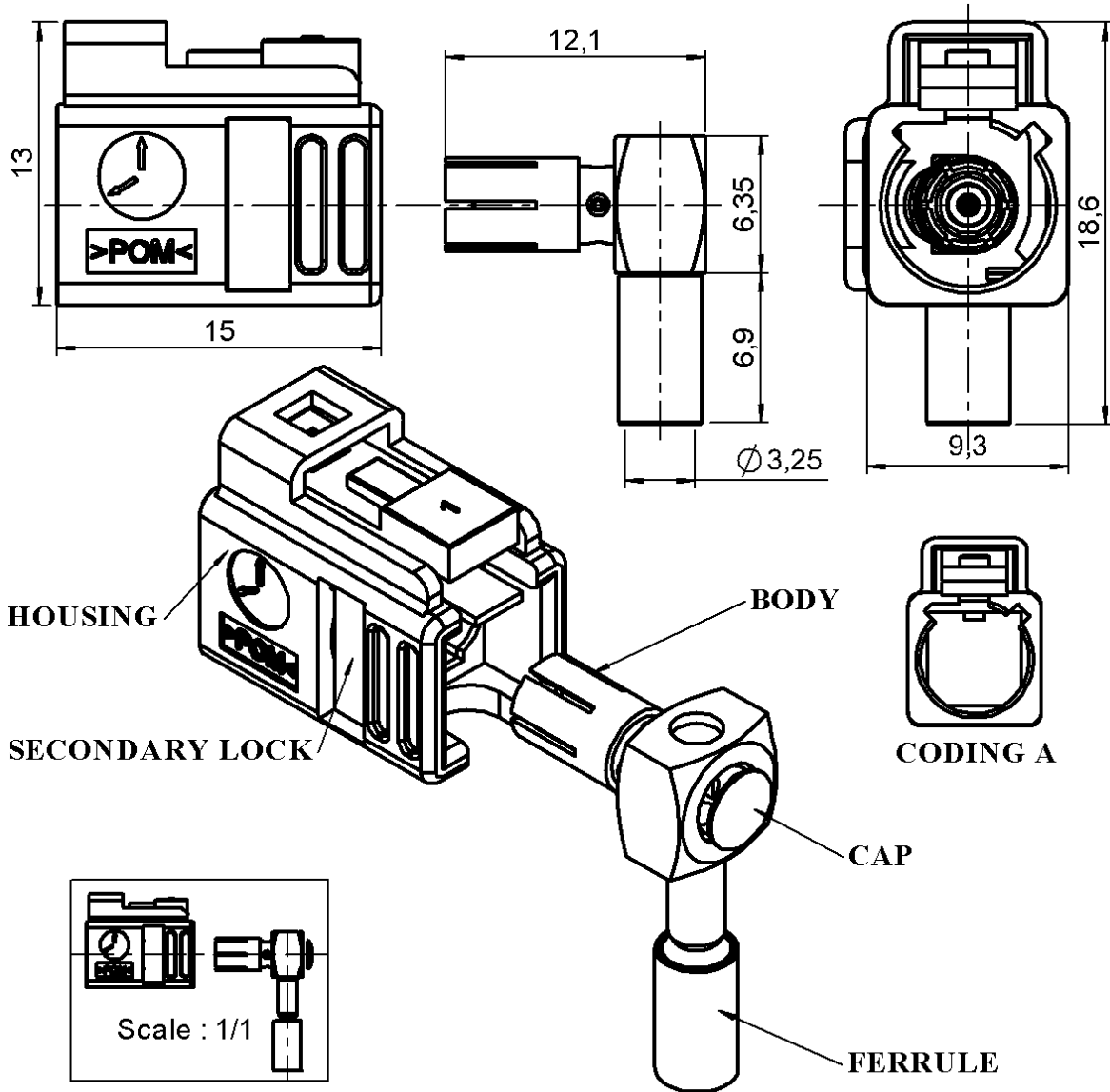

All dimensions are in mm.



COMPONENTS	MATERIALS	PLATINGS (µm)	
BODY	BRASS	NICKEL .	
CENTER CONTACT	BRONZE	GOLD OVER NICKEL	
OUTER CONTACT	BRONZE	NICKEL .	
INSULATOR	PTFE		
GASKET	-		
OTHERS PARTS	BRASS	NICKEL .	
HOUSING	Polyoxyméthylène (POM)	UL CLASSIFICATION	COLOR
Secondary Lock	Polyoxyméthylène (POM)	UL 94V-2	BLACK RAL9005
		UL 94V-2	PURPLE RAL4003

*According with FAKRA specifications

Issue : 0036 A

In the effort to improve our products, we reserve the right to make changes judged to be necessary.



R/A COAX PLUG+HOUSING

R197.120.A00

CABLE 2.6/50

Series : SMB
CARLOCK

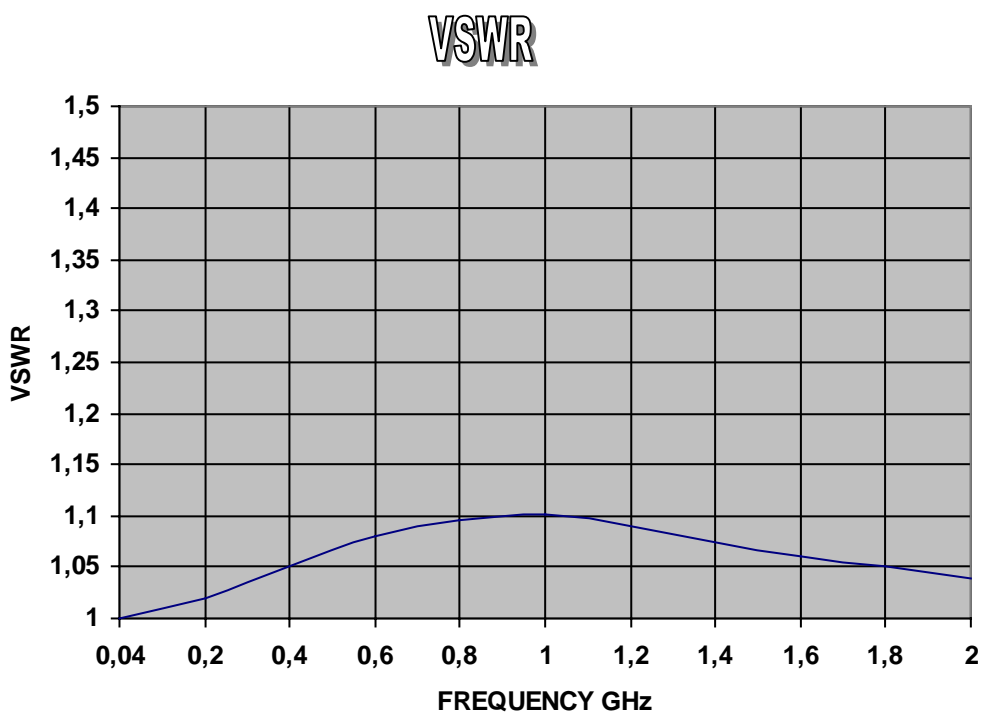

Issue : 0036 A

In the effort to improve our products, we reserve the right to make changes judged to be necessary.





R/A COAX PLUG+HOUSING

R197.120.A00

CABLE 2.6/50

Series : SMB
CARLOCK

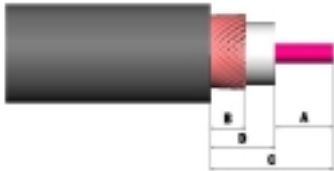
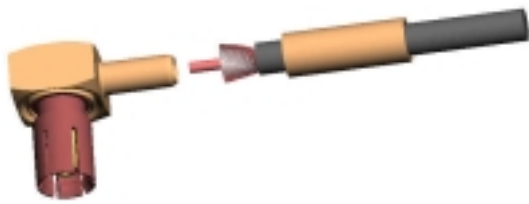
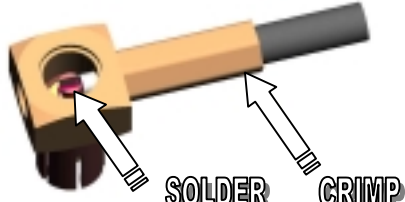
RECOMMENDED MOUNTING PROCEDURE

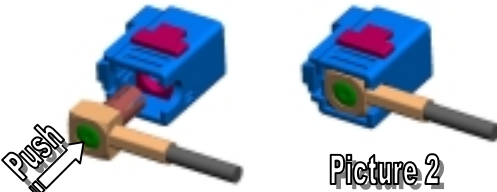
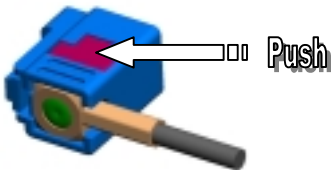
<ul style="list-style-type: none"> • Slide onto the cable the ferrule • Strip the cable 	
<p>2</p> <ul style="list-style-type: none"> • Fan the braid • Push connector body under the braid • Slide the ferrule on the braid (in direction F) 	
<p>3</p> <ul style="list-style-type: none"> • Crimp the ferrule with crimping tool R282.211.000 (Hex:3.25) or crimping tool R282.293.000 (M22520/5-01) + dies R282.235.003 (M22520/5-03) • Solder inner conductor 	
<p>4</p> <ul style="list-style-type: none"> • Place the cap • Press cap flush or slightly below surface of body assembly 	
<p>5</p> <ul style="list-style-type: none"> • Push the coax in the housing till it snap on (according to picture 2) 	
<p>6</p> <ul style="list-style-type: none"> • To secure the coax inside the housing , push the secondary lock in final position (until it click on) 	

Issue : 0036 A

In the effort to improve our products, we reserve the right to make changes judged to be necessary.

